

# Master Abschlussarbeit

## Berghain in Wuppertal

### Fabrikumnutzung und Erweiterung



Lageplan 1:500

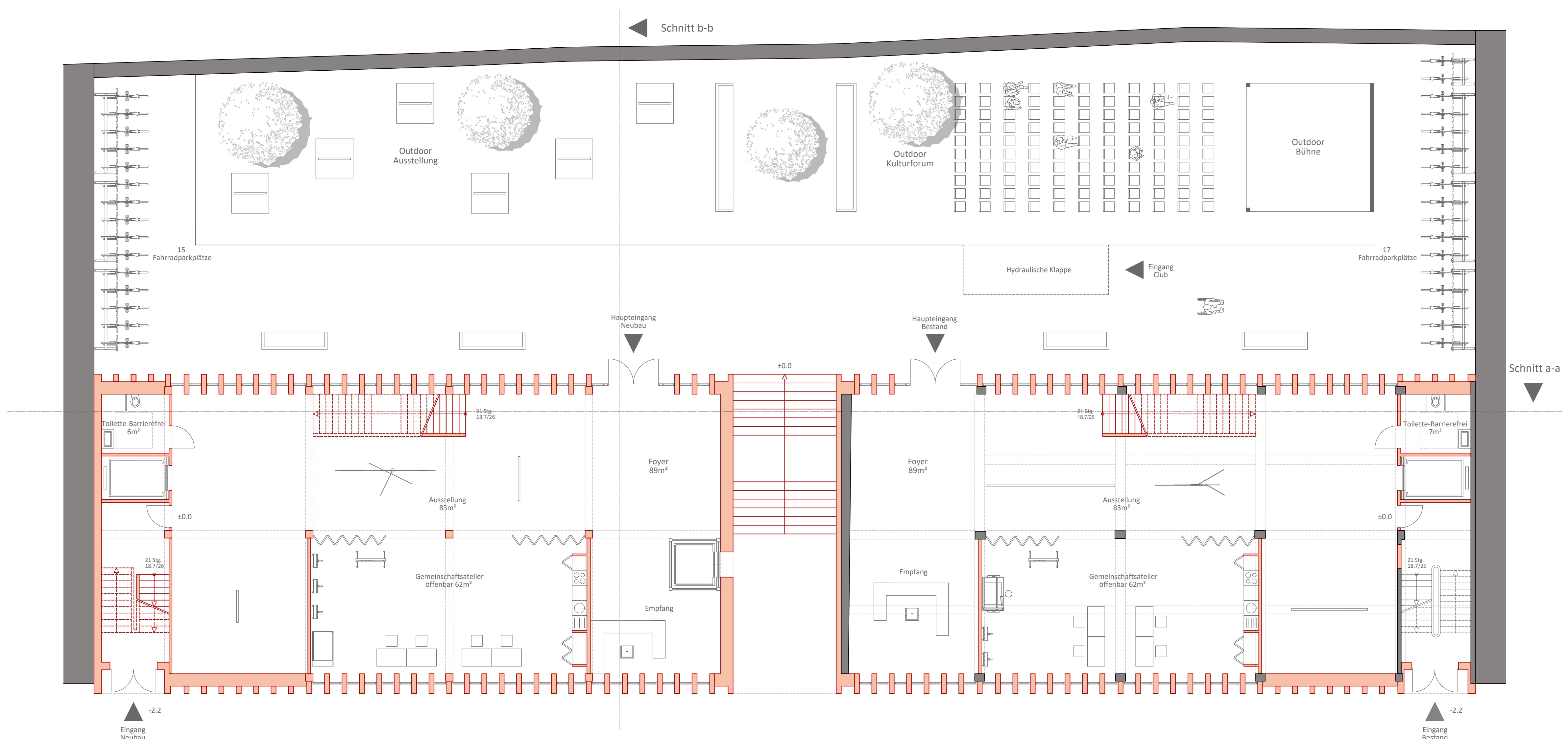

Grundriss 1:100 Erdgeschoss

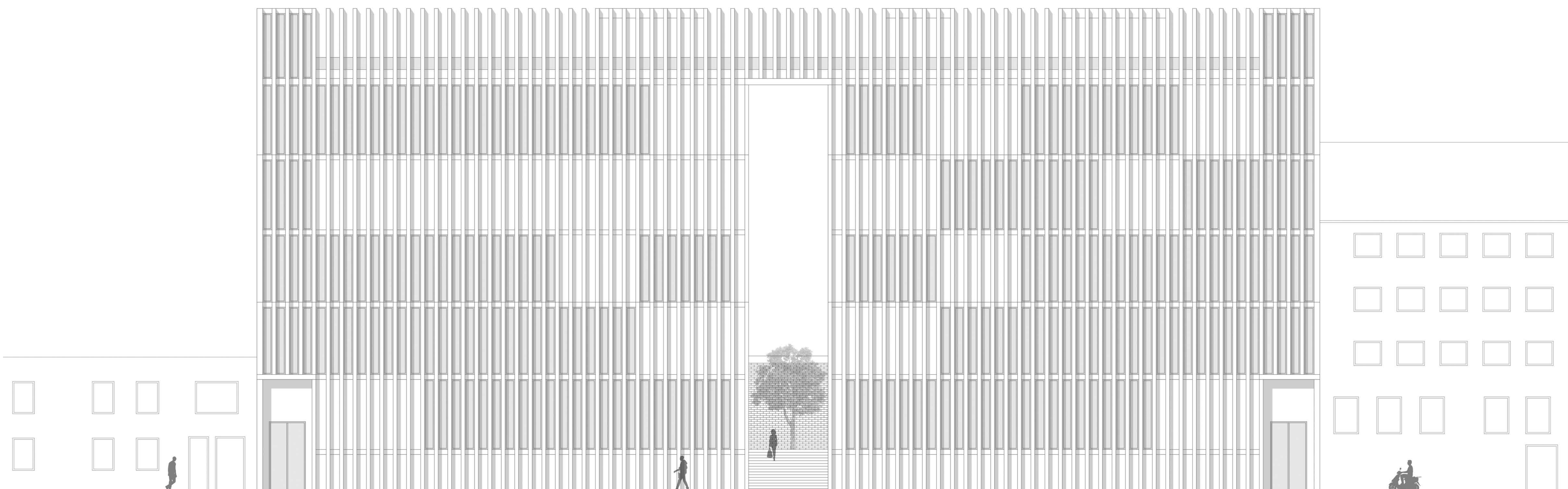

Ansicht 1:100 Wittensteinstraße



Perspektive Siegesstraße

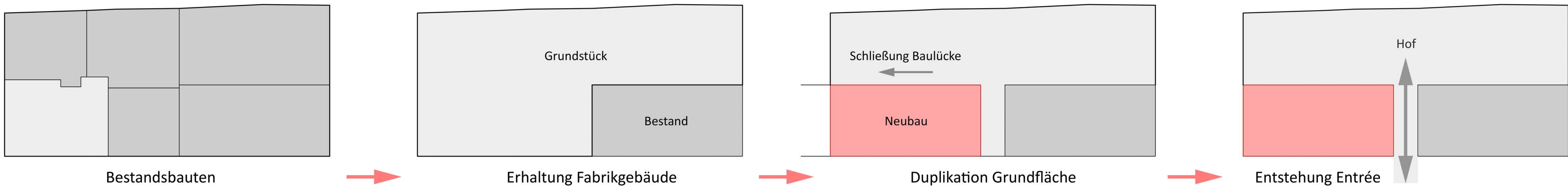

Piktogramm

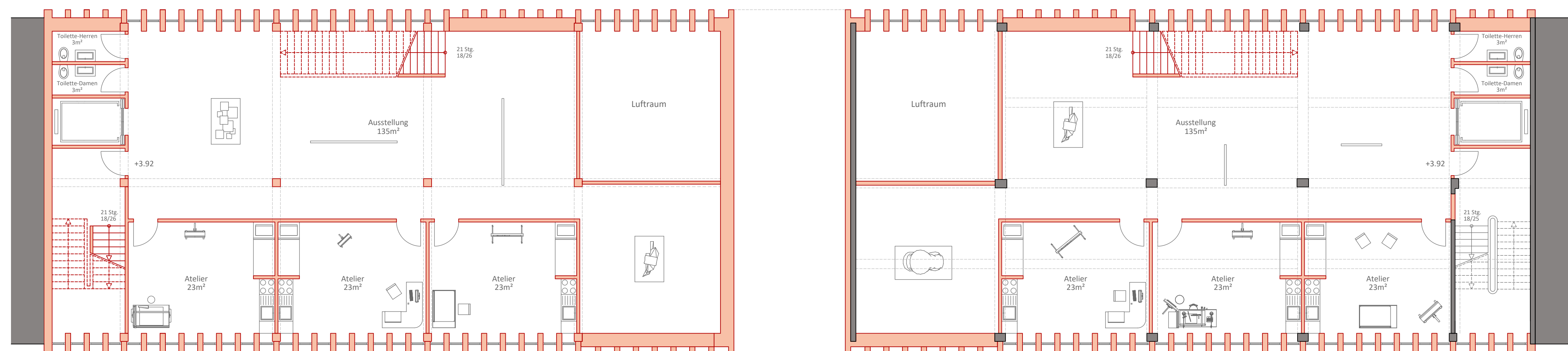

Grundriss 1:100 1. Obergeschoss

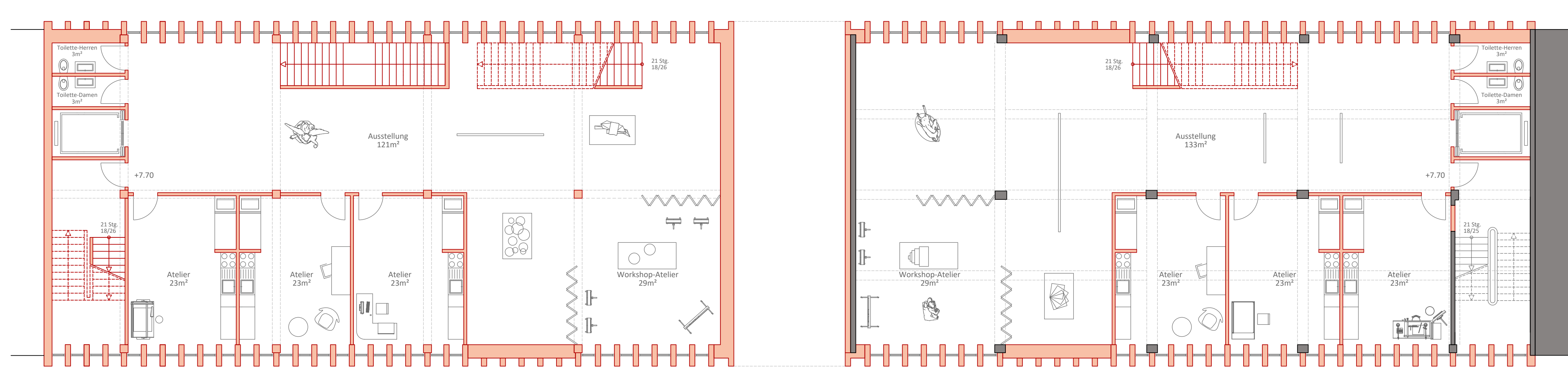

Grundriss 1:100 2. Obergeschoss

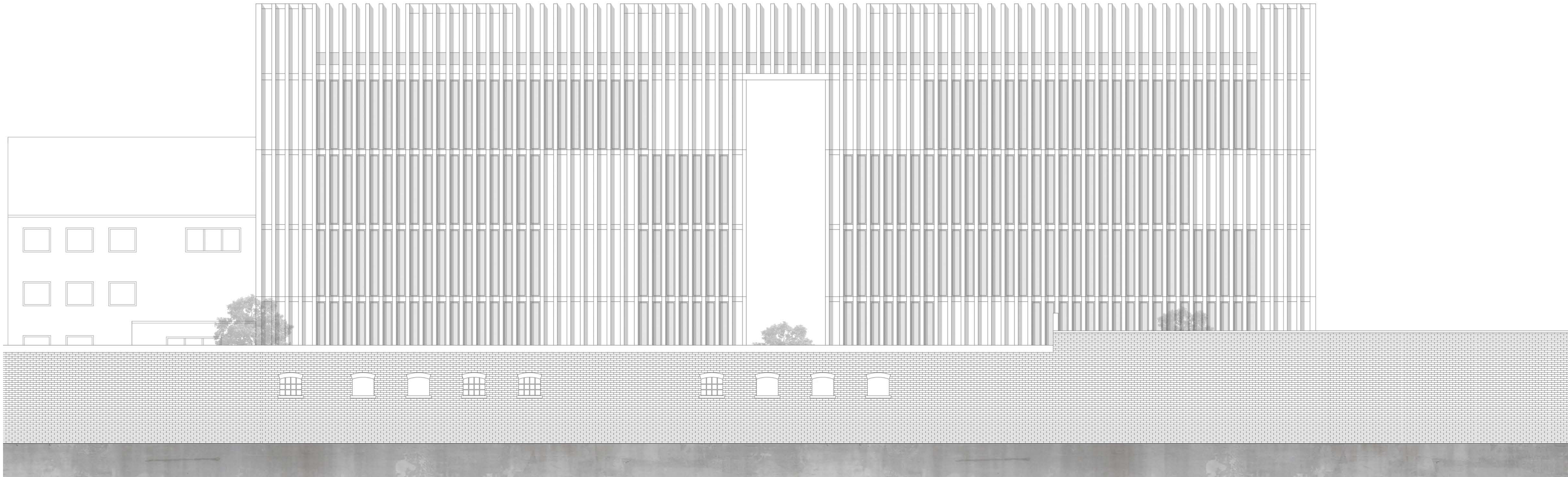

Ansicht 1:100 Siegesstraße



Perspektive Saal

Perspektive Wittensteinstraße

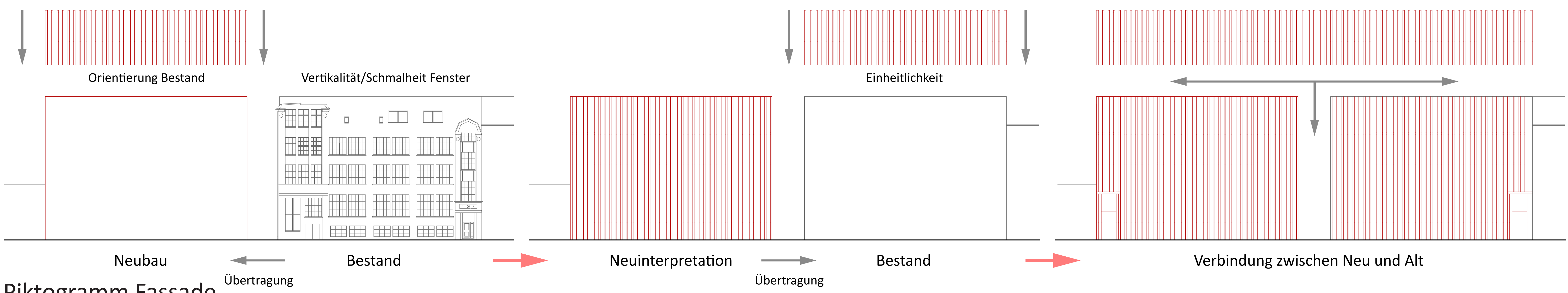

Piktogramm Fassade

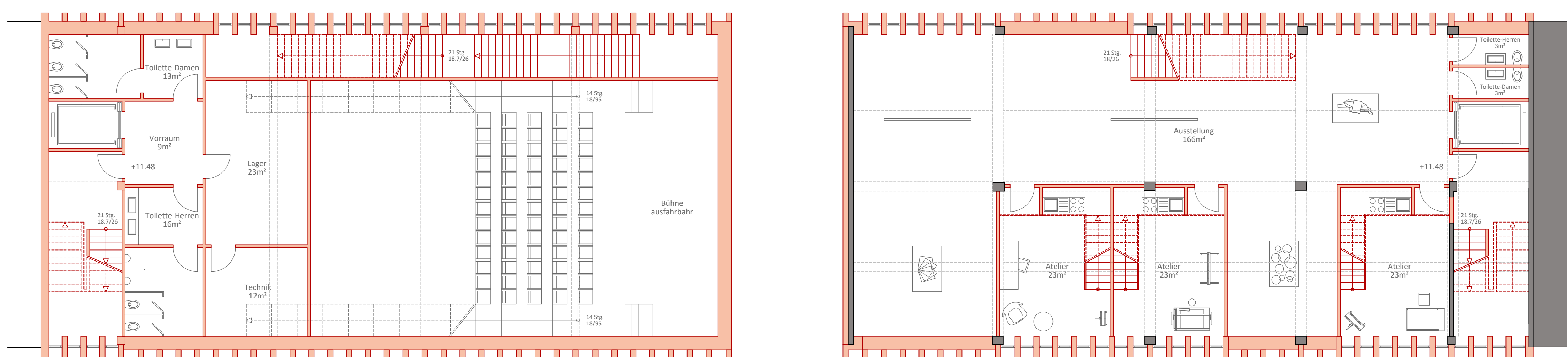

Grundriss 1:100 3. Obergeschoss

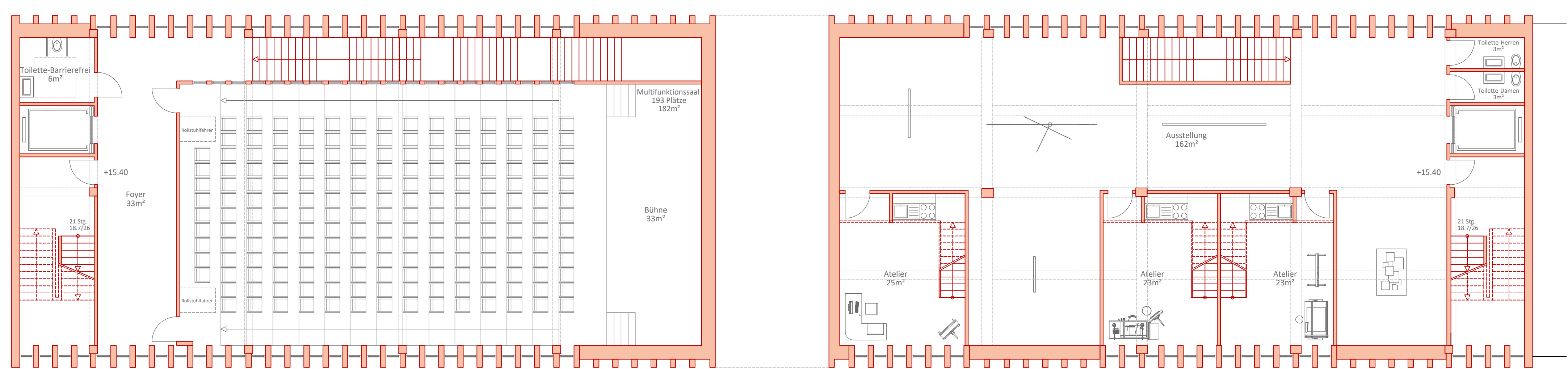

Grundriss 1:100 4. Obergeschoss

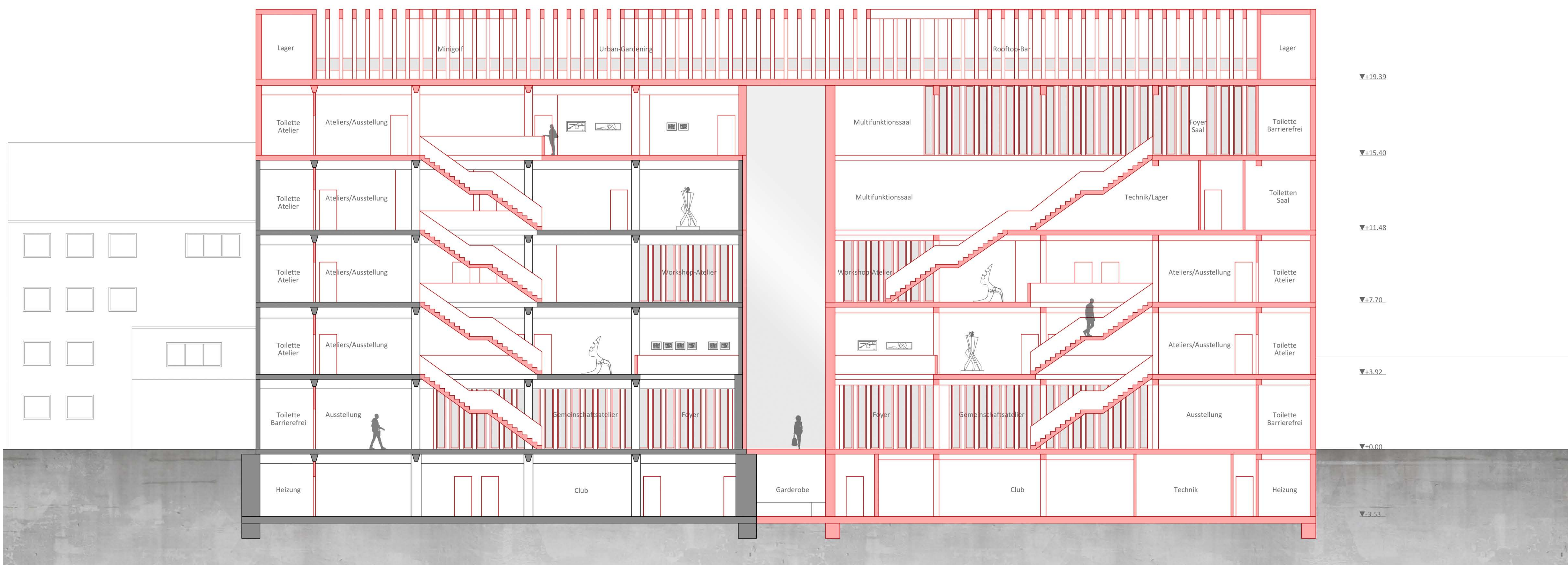

Schnitt a-a 1:100



Perspektive Club

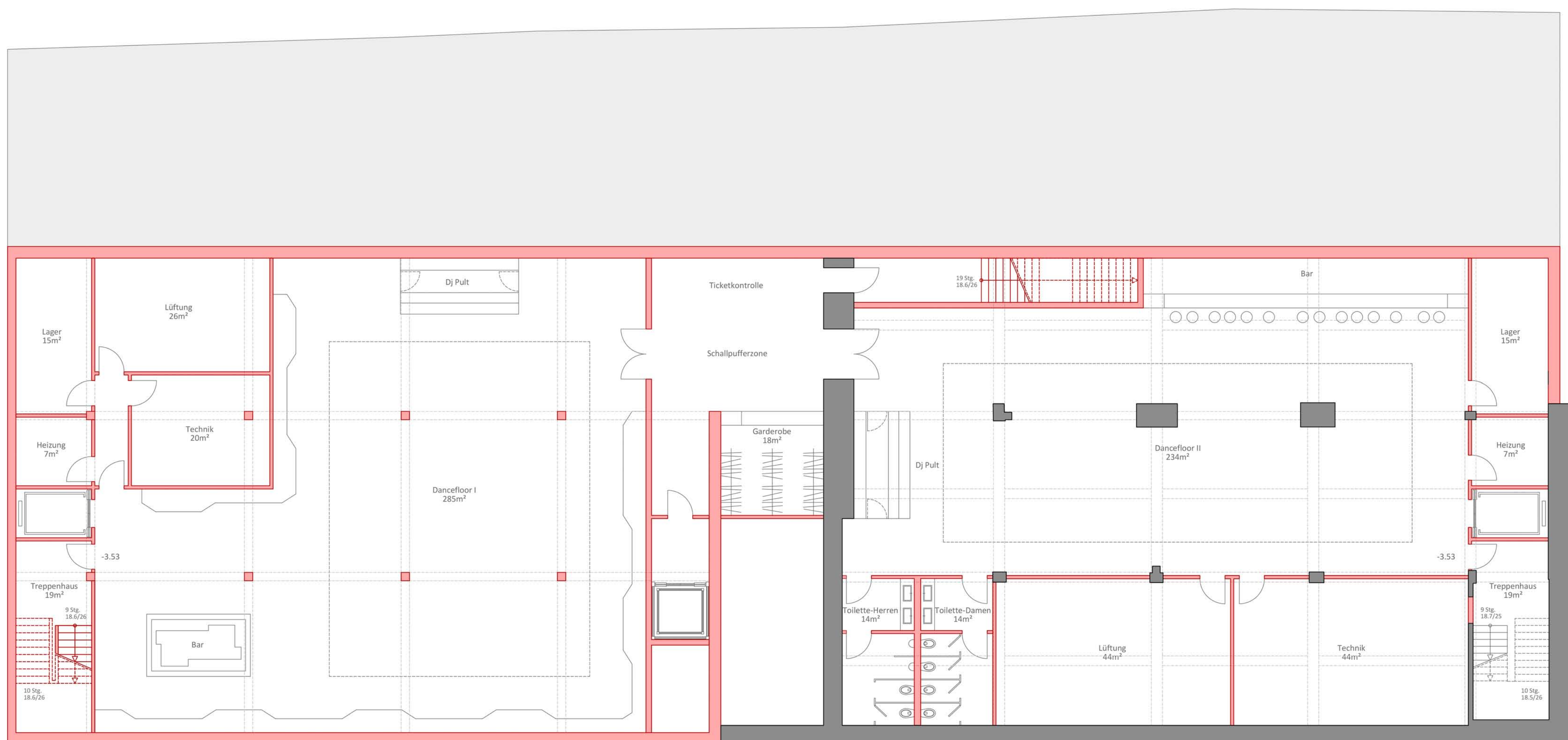

Grundriss 1:100 Untergeschoss

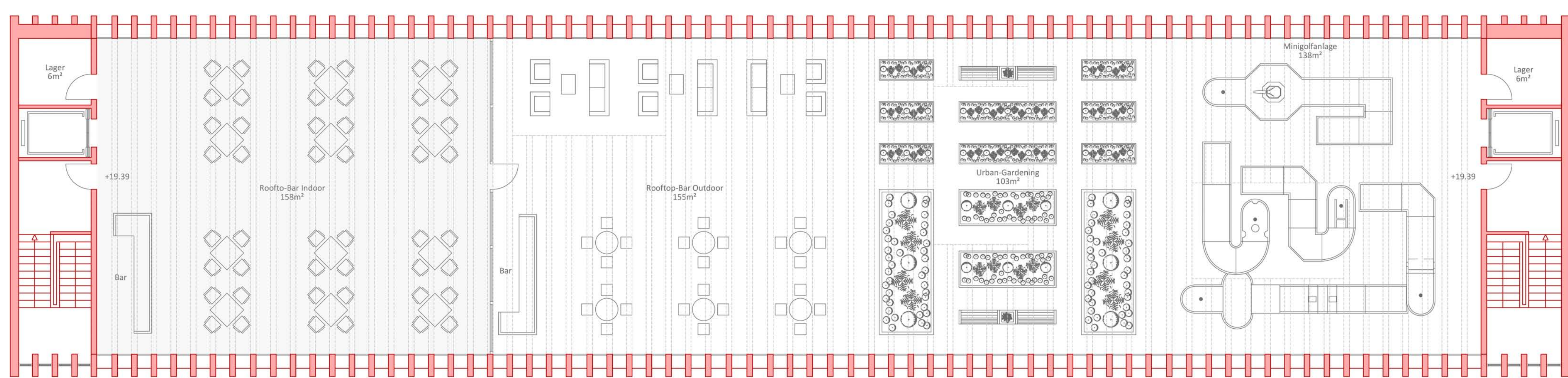

Grundriss 1:100 Dachgeschoss

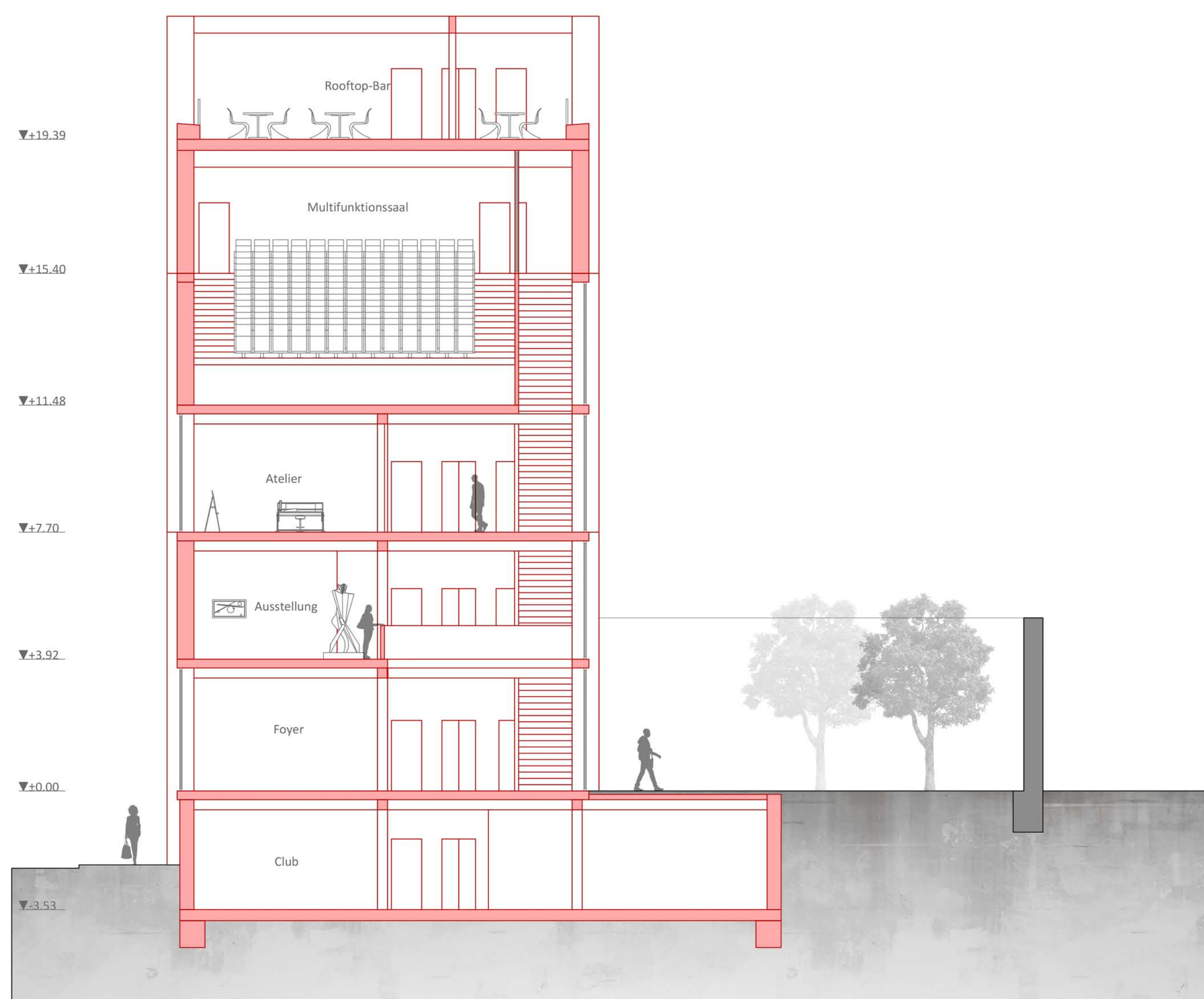

Schnitt b-b 1:100

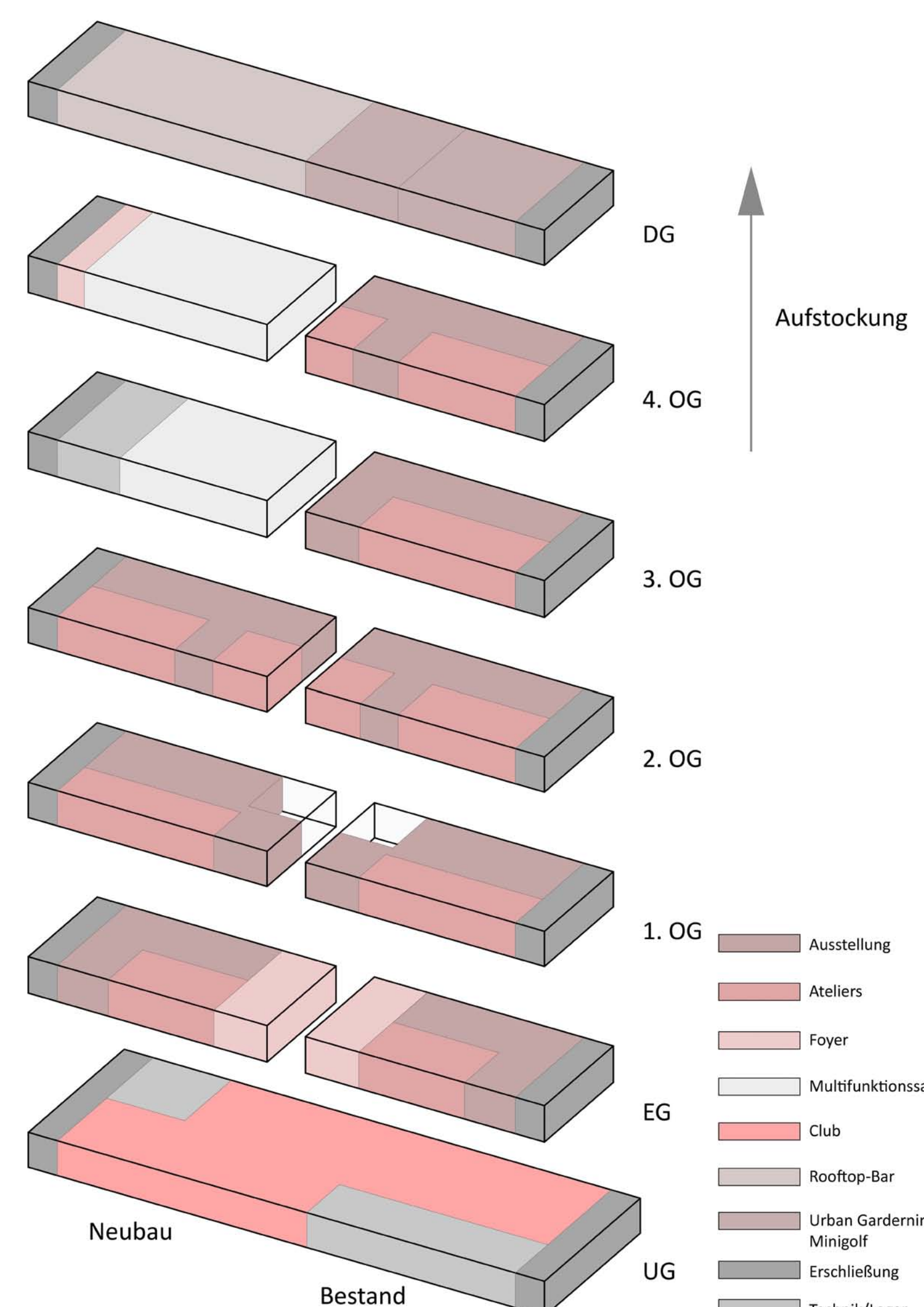

Isometrie Nutzung

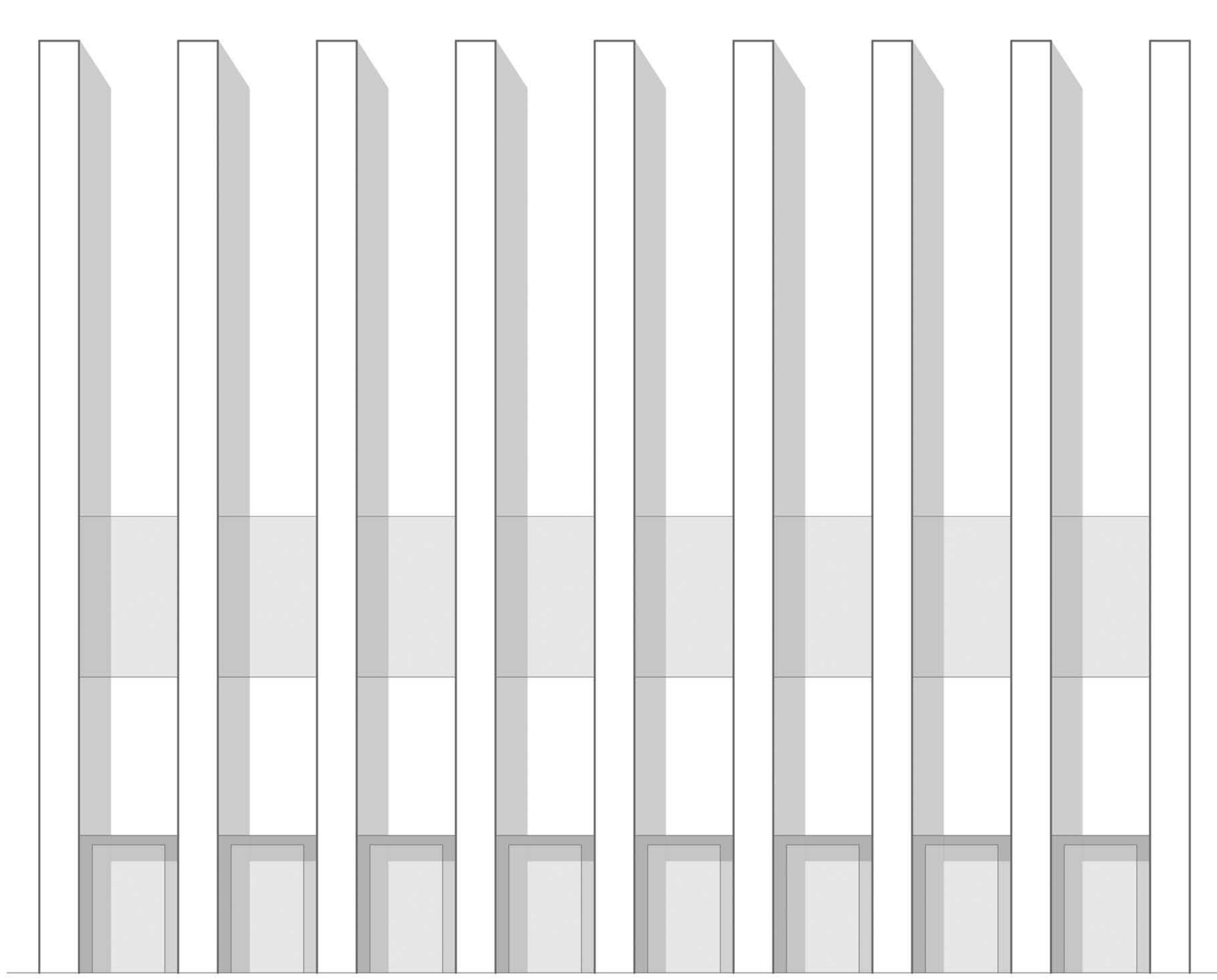

**Attika**  
 Betonfertigteilplatte 70-120mm  
 Brüstungselement Glas  
 Winkelplattenanker  
 EPS-Wärmedämmung 60mm  
 EPS-Wärmedämmung 100mm  
 Abdichtung  
 Druckschraube  
 Stahlbeton 300mm

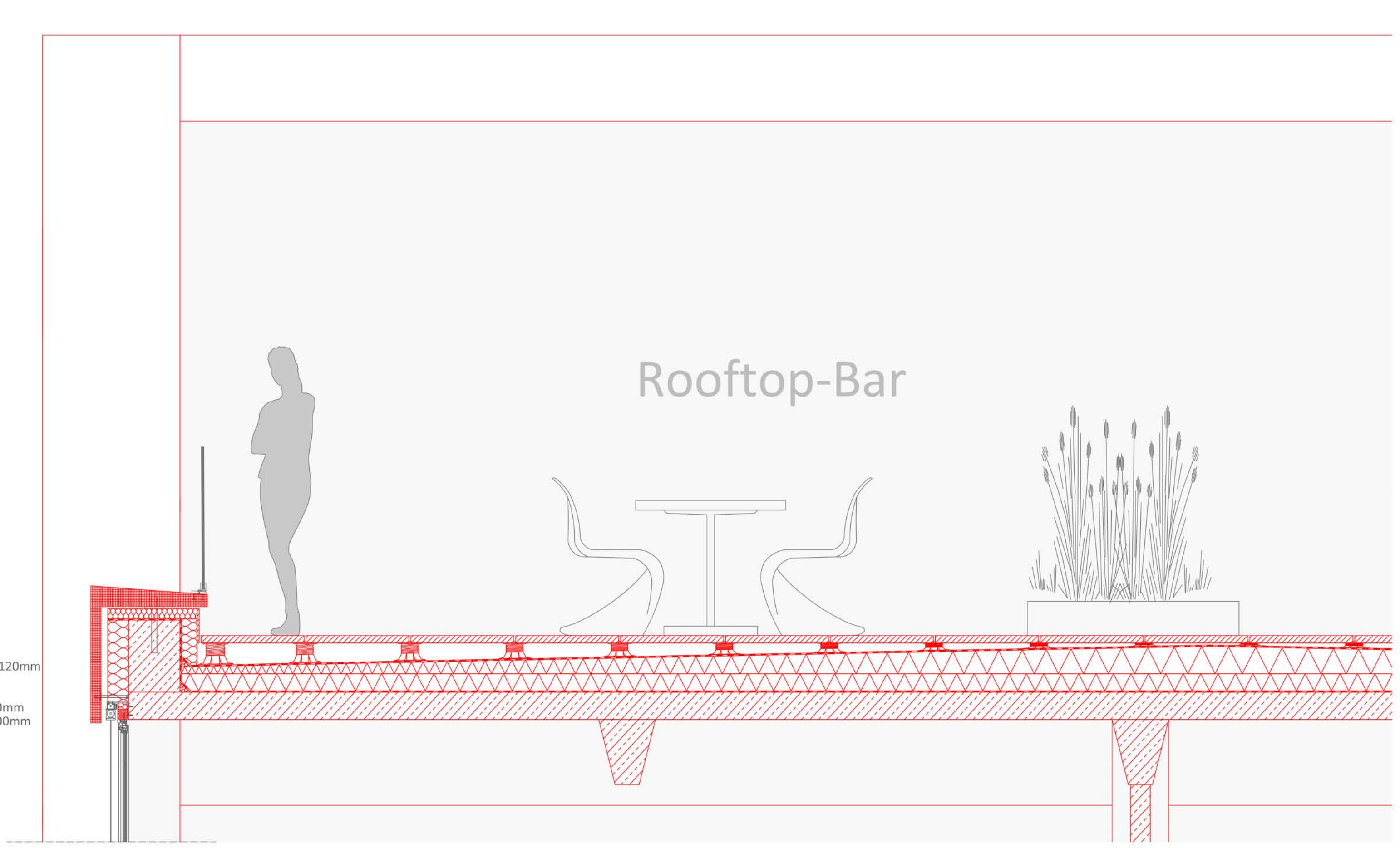

**Dach**  $\nabla +19.39$   
 Betonplatten 600x600x40mm  
 Stielträger selbstnivellierend  
 Abdichtungsüberlage  
 Dämmstoffteil Randbereich  
 Gefälledämmung XPS 140-260mm  
 Dampfsperre  
 Voranstrich  
 Stahlbeton 160mm  
 Stahlbetonunterzüge

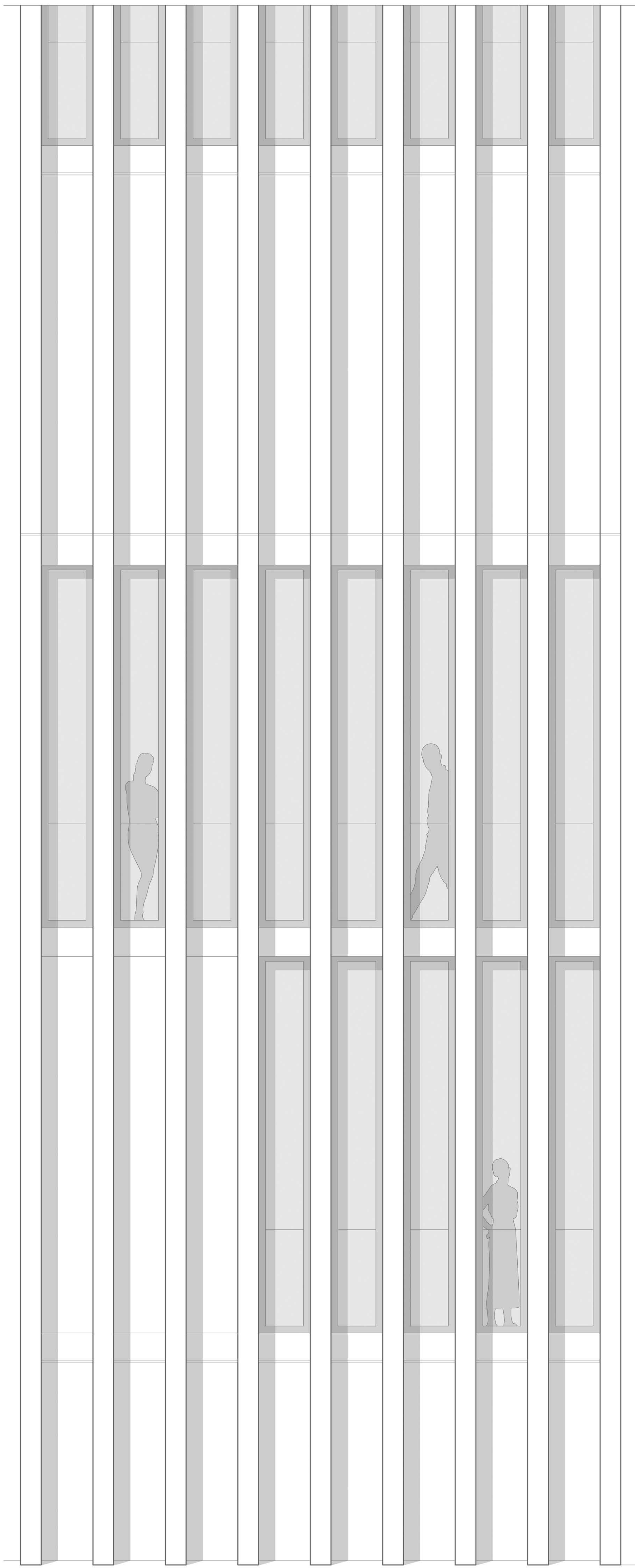

**Außenwand**  
 Betonfertigteilplatte 60mm  
 Luftschicht 40mm  
 Hängezuganker  
 Druckschraube  
 EPS-Wärmedämmung 120mm  
 Stahlbeton 300mm

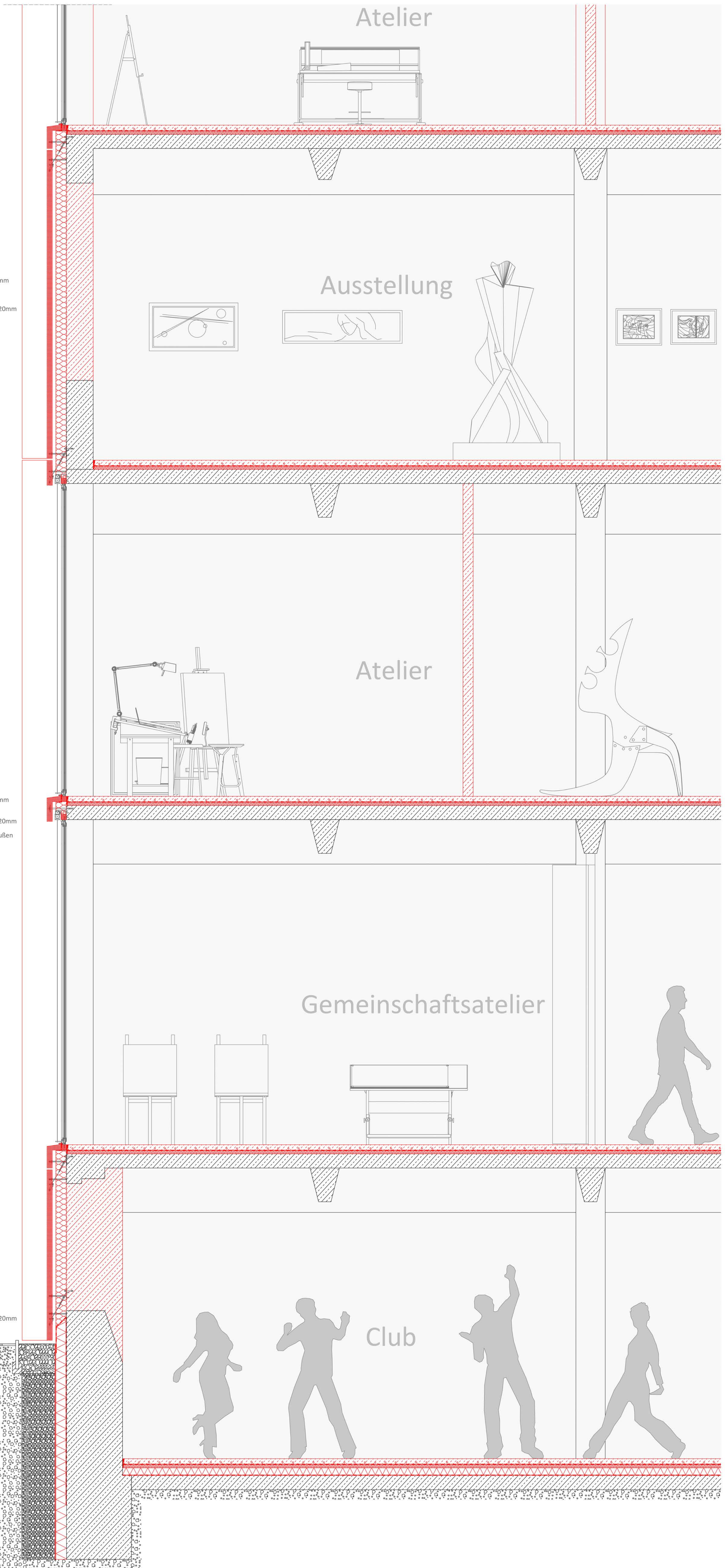

**Decke**  $\nabla +11.48$   
 Sichtstrich 60mm  
 Randdämmstreifen 10mm  
 PE-Folie  
 Trittschalldämmung 35mm  
 Stahlbeton 160mm  
 Stahlbetonunterzüge

**Decke**  $\nabla +7.70$   
 Sichtstrich 60mm  
 Randdämmstreifen 10mm  
 PE-Folie  
 Trittschalldämmung 35mm  
 Stahlbeton 160mm  
 Stahlbetonunterzüge

**Decke**  $\nabla +3.92$   
 Sichtstrich 60mm  
 Randdämmstreifen 10mm  
 PE-Folie  
 Trittschalldämmung 35mm  
 Stahlbeton 160mm  
 Stahlbetonunterzüge

**Decke**  $\nabla \pm 0.00$   
 Sichtstrich 60mm  
 Randdämmstreifen 10mm  
 PE-Folie  
 Trittschalldämmung 35mm  
 Stahlbeton 160mm

**Bodenplatte**  $\nabla -3.53$   
 Sichtstrich 60mm  
 Randdämmstreifen 10mm  
 PE-Folie  
 Trittschalldämmung 35mm  
 XPS-Wärmedämmung 80mm  
 PE-Folie  
 Stahlbeton 160mm

**Decke**  
 Betonfertigteilplatte 60mm  
 Windanker  
 Luftschicht 40mm  
 EPS-Wärmedämmung 120mm  
 3-fach Isolierverglasung  
 Textiler Sonnenschutz außen  
 Vorwandmontage  
 Abdichtung

**Sockel**  
 Kiesschicht  
 Noppenbahn  
 XPS-Wärmedämmung 120mm  
 Blumensdichtung  
 Stahlbeton 630mm

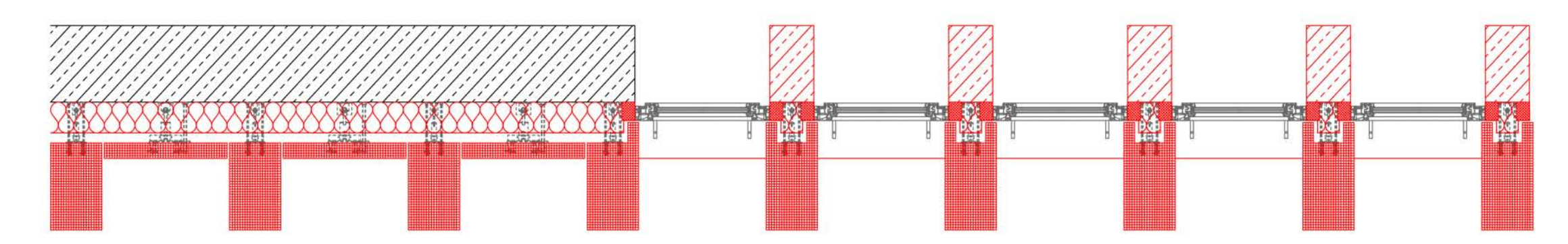

Fassadenschnitt 1:20